

Mini-Fit, CPI™

Compliant Pin Interface

Headers



FEATURES AND SPECIFICATIONS

molex® Mini-Fit CPI™ Introduction

This product line offers great design flexibility by allowing you to connect:

Mini-Fit, Jr.

- Mini-Fit, Jr. 5556 Female crimp terminal
- Mini-Fit, Jr. 5557 receptacle with positive lock (wire-to-board)

Mini-Fit, BMI

- Mini-Fit, BMI 42474 Blind mating receptacle (wire-to-board)
- Mini-Fit, BMI 42385 Blind mating header receptacle (board-to-board)

The Mini-Fit, CPI is a compliant pin interface header from the well-known Mini-Fit family. This product is designed for high current/high density applications which require press fit headers. It is appropriate for both power and signal applications as it can carry currents of up to 8 amperes per circuit.

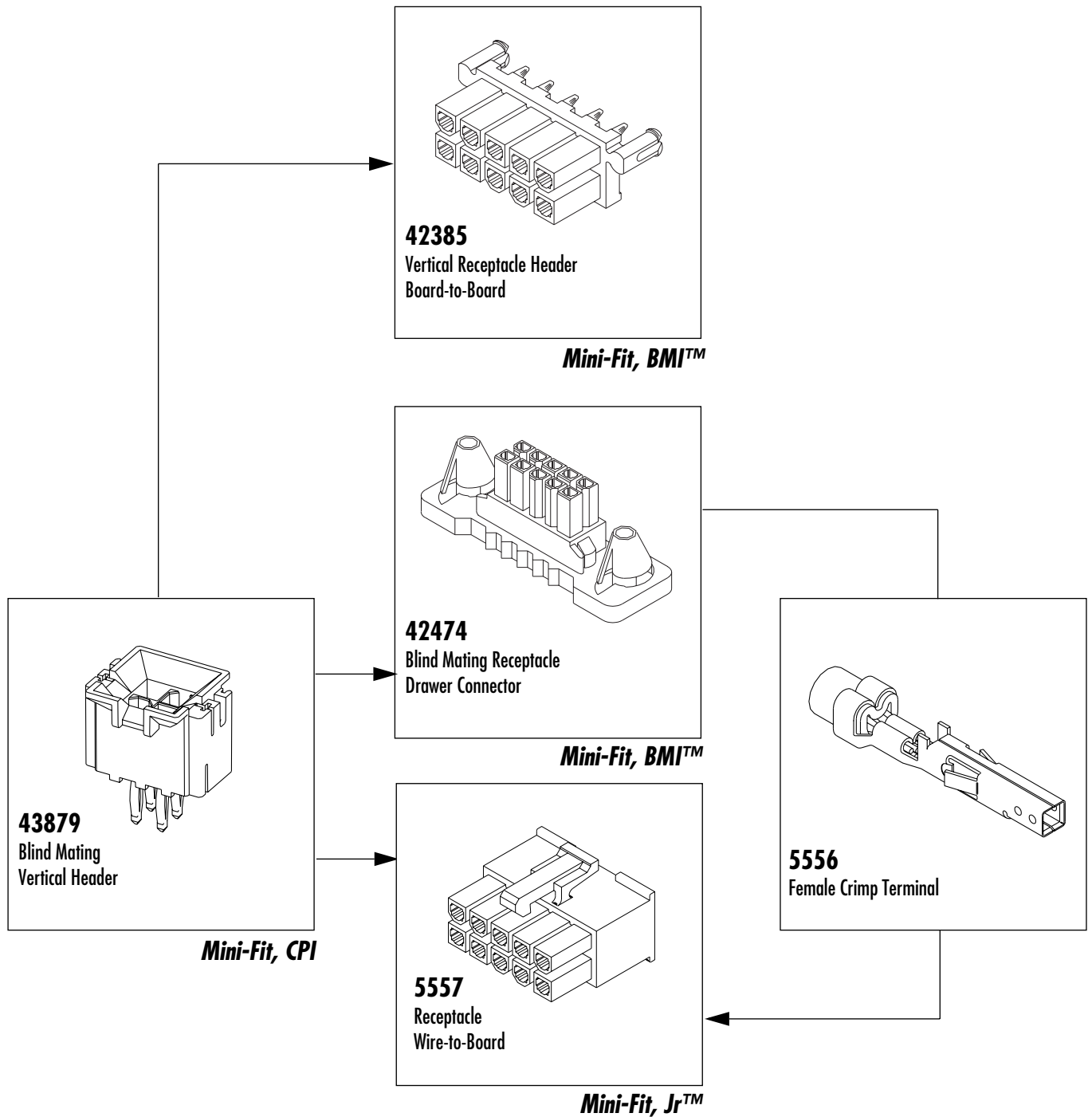

FEATURES AND SPECIFICATIONS

Features and Benefits

- Press-fit pin requiring no soldering
- Blind mating vertical header
- Designed for multiple board thicknesses of .094" and greater

Reference Information

Designed in: Millimeters
 Packaging: Tray
 Product Specifications: PS-43879-001
 UL File No.: E29179
 CSA File No.: LR19980
 TUV License No.: R75142
 Mates with: 5557, 42385 and 42474 receptacles

Electrical

Voltage: 600V
 Current: 8.0A max.
 Contact Resistance: 10mΩ max.
 Dielectric Withstanding Voltage: 1500V
 Insulation Resistance: 1000 MΩ min.

Mechanical

Insertion Force to PCB: 196.13N (44.09 lb) per circuit max.
 Retention Force to PCB: 49.03N (11.02 lb) per circuit min.
 Mating Force: 6.86N (1.54 lb) per circuit max.
 Unmating Force: 3.43N (0.771 lb) per circuit min.
 Normal Force: 1.96N (0.44 lb) min.
 Durability: 30 cycles

Physical

Housing: 4/6 nylon, UL 94V-0
 Contact: Phosphor Bronze
 Plating: Tin or Gold
 Operating Temperature: -40 to +105°C
 (Including 30°C terminal temperature at full current)



4.20mm (.165") Pitch Mini-Fit, CPI™ Compliant Pin Interface

43879

Dual Row, Vertical Header

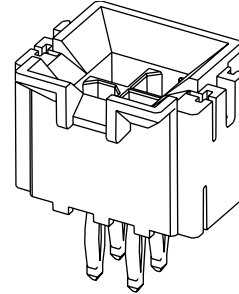

DIMENSIONS

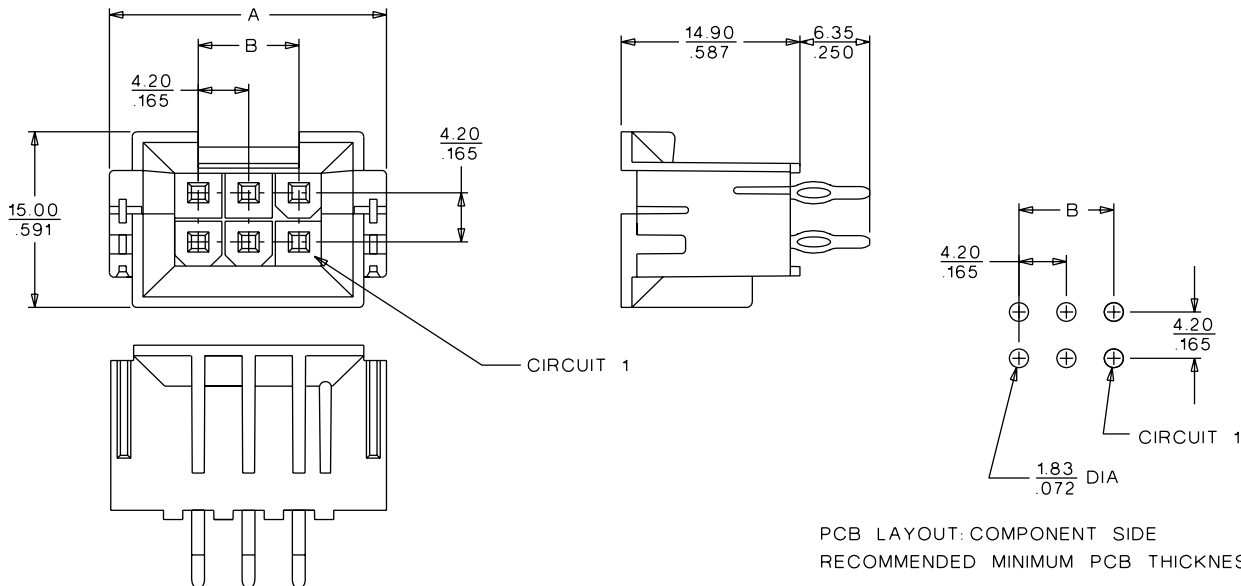

PCB LAYOUT: COMPONENT SIDE
 RECOMMENDED MINIMUM PCB THICKNESS: $\frac{2.39}{.094}$

ORDERING INFORMATION

Circuits	Order No.		Dimension	
	Tin Plated	Gold Plated	A	B
4	43879-0022	43879-0033	18.81 (.740)	4.20 (.165)
6	43879-0023	43879-0034	23.01 (.906)	8.40 (.331)
10	43879-0025	43879-0036	31.41 (1.237)	16.80 (.661)
14	43879-0027	43879-0038	39.81 (1.567)	25.20 (.992)
18	43879-0029	43879-0040	48.21 (1.898)	33.60 (1.323)
24	43879-0032	43879-0043	60.81 (2.394)	46.20 (1.819)

Insertion Tool with Manual Press

This application tooling was designed specifically to press in the Mini-Fit, CP connector series 43879

Features

- Tooling rotates in 90° increments allowing Mini-Fit to be positioned in four different orientations
- Laser locator aids in identifying pin orientation or PC board
- Adjustable board thickness ranging from .062" to .300"
- Accommodates left and right hand operators
- Polarization of tooling allows connector to be loaded in the proper orientation
- 4 to 24 circuits with change parts included
- Fits Molex standard Manual Press

Specifications

Weight: Including Press—24.1 kg (53 lbs.)

Size: Including Press

Height—498mm (19.6")

Length—269mm (10.6")

Depth—152.4mm (6")

Rate: 120 connectors/hr depending on operator skill



Ordering Information

Description	Order No.	Product No.
Manual Press and Tool Kit	62200-6900	43879
Tool Kit Only	62200-5800	43879
Manual Press	11-31-6356	

Press-In Tool

Features

- Includes one pin holder, one backing plate and 24 alignment pins
- This locking assembly may be used in a wide variety of flat platen presses
- A separate board support palette is required by customer
- The connector is pressed into the board from the top
- Tool accommodates the full range of product from 4 to 24 circuits with removable pin:

Specifications

Weight: Assembly—0.91 kg (2 lbs.)

Size: Assembly

Height—19.5mm (0.8")

Length—54.5mm (2.1")

Depth—31.8mm (1.3")

Rate: 150 connectors/hr dependent on operator skill

Ordering Information

Description	Order No.	Product No.
Press-In Tool	62200-9400	43879

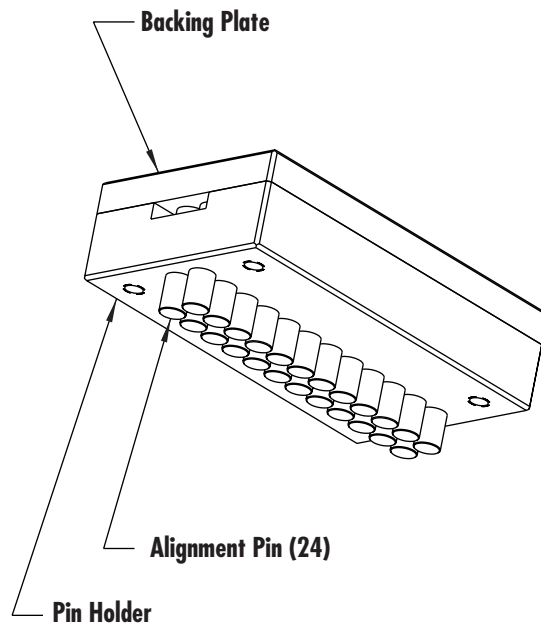

INTERNETWORKING SYSTEMS

- Concentrators
- Hubs and Routers
- LANS
- WANS
- Servers
- Backplanes

TELECOMMUNICATIONS

- Hubs and Routers
- Servers
- Backplanes

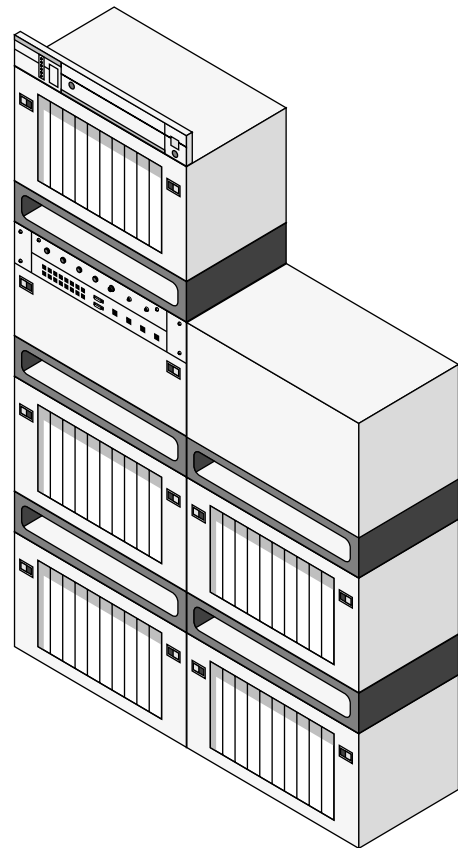
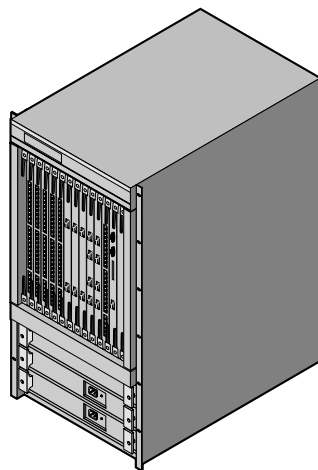
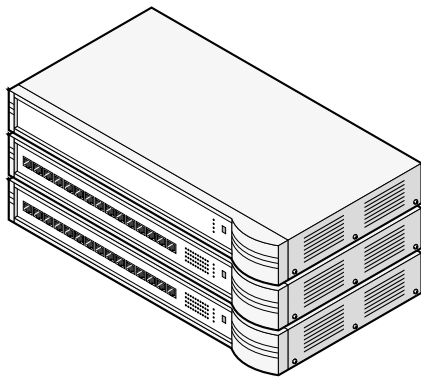



Bringing People & Technology Together, WorldwideSM

Americas Headquarters

Lisle, Illinois 60532 U.S.A.
Tel: 1-800-78MOLEX
Fax: 630-969-1352

Far East North Headquarters

Kanagawa, Japan
Tel: 81-462-65-2324
Fax: 81-462-65-2361

Far East South Headquarters

Jurong, Singapore
Tel: 65-268-6868
Fax: 65-265-6044

European Headquarters

Munich, Germany
Tel: 49-89-413092-0
Fax: 49-89-401527

Corporate Headquarters

2222 Wellington Court
Lisle, Illinois 60532 U.S.A.
Tel: 630-969-4550
Fax: 630-969-1352

Visit our Web site at <http://www.molex.com>